



VOYAGER/VMES

VIRTUAL MULTI-ENCLAVE SYSTEM

Integrated | Virtualized | Compatible | Transportable

KLAS
GOVERNMENT



VOYAGER/VMES

VIRTUAL MULTI-ENCLAVE SYSTEM

Integrated | Virtualized | Compatible | Transportable

Background

Today's battlefield has evolved into a complex and integrated environment that requires connected communications to be successful. Warfighters on the move need to access critical information across multiple domains because information is power. The need to intercommunicate with coalition partners and access data from different classification levels is an absolute must. As a result, it places a significant burden for deployed units to transport, manage, and operate multiple systems which are often not integrated nor interoperable.

The problem vs. our solution

The need for highly mobile and interoperable communications is critical to the maneuverability of our forces in environments that rarely conform to traditional IT requirements. Current solutions are extremely heavy, take up too much space, power, require special cooling, can not be deployed quickly, and are extremely complex to operate and maintain.

Klas can today deliver this capability as commercial off the shelf equipment and integrate it with the current components and systems the military already owns. Voyager is a system that was built to meet the mission requirements of expeditionary communication units. We are now able to provide the warfighter with the ability to deploy capabilities previously limited to Special Operations Forces-type units in a cost effective and battle proven platform. Voyager is designed to scale vertically and horizontally to rapidly support small and large team operations and adapt to changing mission requirements.

Benefits and key features

The Voyager system enables the warfighter to observe, orient, decide and act faster than the enemy. In addition, it enables reliable communications anywhere, anytime in all domains, in all environments. Benefits include:

- The system is airline transportable and has built in wheels allowing enhanced mobility
- Operates on AC and DC worldwide power and includes it's own battery backup using military-standard 2590 batteries
- The Voyager system dramatically lowers the total deployed footprint
- Savings on total cost and resources needed
- Software Defined Networking (SDN) ready
- Supports multiple transmission paths
- Commercial Off the Shelf Technology packaged in Line Replaceable Unit modules
- Additional enclaves may be added for connectivity for coalition networks (or security enclaves), by adding additional modules or reconfiguring existing enclaves. Multiple cases may be stacked to scale up capacity
- Interoperability with other Government/Military systems

Network Architectural Diagram

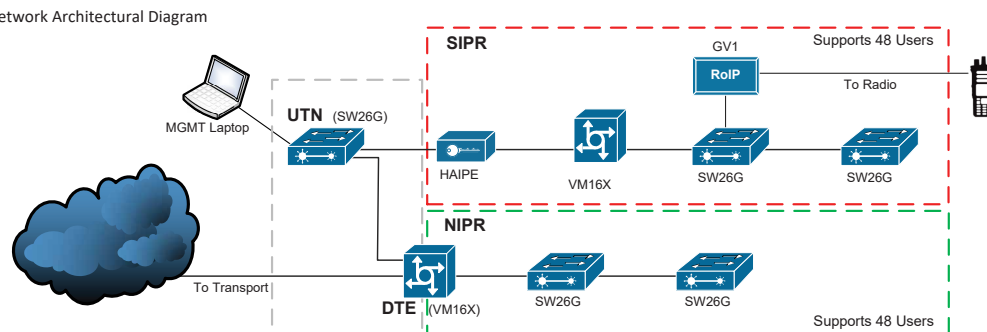

Module Layout

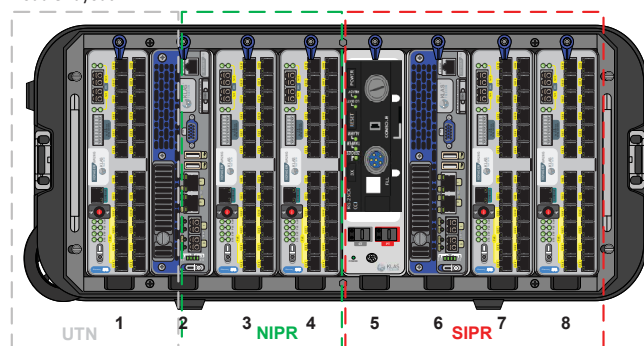

LEGEND	
Slot	Description
1	VoyagerSW26G
2	VoyagerVM16X
3	VoyagerSW26G w/ Voyager 1
4	VoyagerSW26G w/ Voyager 1
5	VoyagerHAiPE w/ KG-250X
6	VoyagerVM16X
7	VoyagerSW26G w/ Voyager 1
8	VoyagerSW26G w/ Voyager 1
9	CISTECH GV1-2010-D1A-R
10	Cradlepoint IBR900



KLAS

GOVERNMENT

Klas Government makes the world's most powerful and reliable technology in its field. It works where nothing else will. It is the best-made, best value technology for the extreme, tactical edge of the network.

For more information, please contact:

Klas Government

450 Springpark Place, Suite 1200, Herndon, VA 20170

571-375-2515 | sales@klasgov.com